

RR MULTI SERIES

RR-FW-AB-75-01 - ADJUSTABLE BENCH

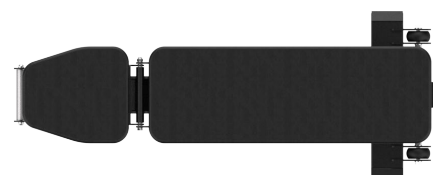
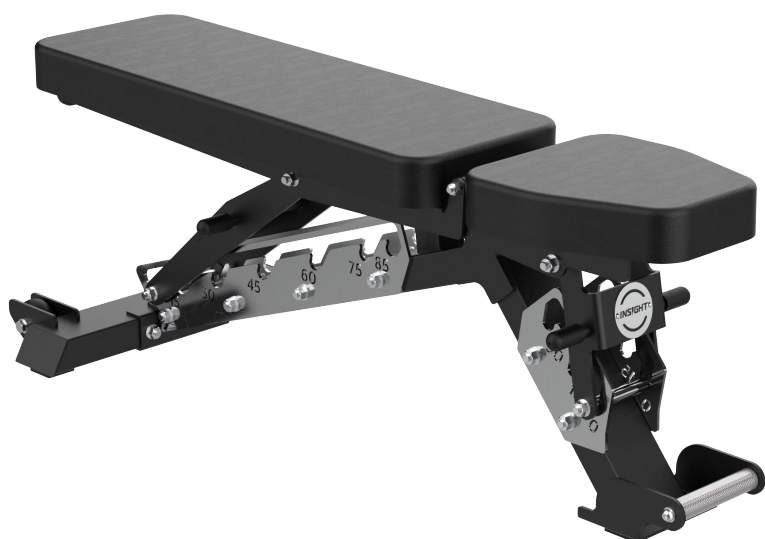

PRODUCT OVERVIEW

The RR-FW-AB-75-01 features a solid square-tube frame for a stable, heavy-duty build. Knurled metal handles provide a secure, sweat-resistant grip, while front-mounted transport wheels make repositioning effortless for use with various training stations.

Its 8-position adjustable back pad (-10° to 85°) supports a full range of pressing angles—from decline chest press to upright shoulder press—meeting diverse training goals. A wide, high-resilience pad offers stable torso support, ensuring both safety and comfort. The 3-position adjustable seat (0° to 30°) aligns with the pelvis's neutral position at different torso angles, helping users find optimal leverage while reducing lower back strain and improving both safety and performance. An innovative quick-adjust back pad design allows single-handed, precise angle changes both raising and lowering while the sturdy support frame maintains stability. Clear angle markings on each position further enhance ease of use.

SPECIFICATIONS & KEY FEATURES

Specifications

Dimension:	1315*520*490mm
Net Weight:	46kg
Max Load Capacity:	150kg
Main Frame Tubing:	J50x100x2.5
Standard Color Scheme:	Black 2852

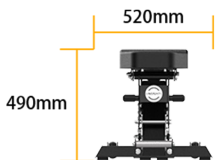
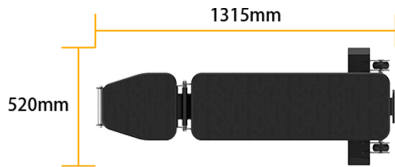
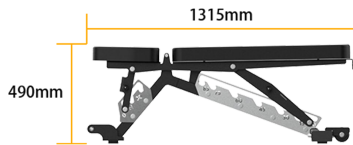

Product Features



Knurled Metal Handles

Comfortable, non-slip grip for secure handling during training.



8-Position Back Pad Adjustment

Supports a full range of pressing movements from decline to upright, meeting varied training needs.

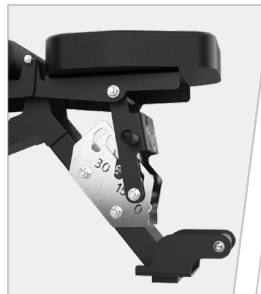

3-Position Seat Adjustment

Aligns with different torso angles to maintain pelvic neutrality, reducing lumbar stress and ensuring safety.



Quick-Adjust Back Pad

Single-handed, effortless adjustment with precise positioning and clearly marked angle indicators for convenience.